



# MODEL T-260 TOWER SPECIFICATIONS





# TOWER SPECIFICATIONS: MODEL T-260 Cooling Tower Systems, Inc.

Design and Operating Conditions		Water Distribution System Construction Materials	
Tower Type:	Counter Flow Induced Draft	Stand Pipe:	PVC
Water Flow Rate (GPM):	177 GPM	Sprinkler Head:	AC
Entering Water Temperature	95°F	Sprinkler Pipes:	PVC
Leaving Water Temperature	85°F	Mechanical Equipment	
Wet Bulb Temperature:	75°F	Fan Unit:	One Unit per Tower
Total Fan BHP:	1.5 HP	Type:	Axial Flow
Total Pump Head:	6.6'	Manufacturer:	CTS
Drift Loss of Water Flow:	0.1%	Diameter:	46"
Evaporation Loss of Water Flow:	0.93%	Blade Material:	AC
Design Wind Load:	30.7 lbs/sq. ft.	Hub Material:	AC
Structural Details		Nominal Air Volume:	14,700 CFM
Overall Diameter:	78 3/4"	Fan Motor	
Overall Height:	74 11/16"	Number of motors:	One Unit per Tower
Dry Weight:	437 lbs.	Type:	Induction
Operating Weight:	1,752 lbs.	Manufacturer:	CTS
Basic Tower Construction Materials		Insulation:	F Class
Tower Support Frame Assembly	-	Rated HP:	1.5 HP
Casing:	FRP	Voltage and phase:	220/440V/3
Casing Supporters	Nylon	Piping Connections	
Cold Water Basin	FRP	Primary Water Inlet Diameter	3"
Filling:	PVC	Primary Water Outlet Diameter:	3"
Filling Supports:	HDGS	Auto fill inlet diameter:	3/4"
Fan Guard	HDGS	Quick fill inlet diameter:	-
Mechanical Equipment Supports:	HDGS	Overflow outlet diameter:	1"
Inlet Louvers:	PVC	Drain diameter:	1"
Bolts, Nuts & Washers:	STS	Water Flow (GPM):	177 GPM
Materials Key			
FRP	Fiberglass Reinforced Polyester	STS	Stainless Steel
HDGS	Hot Dipped Galvanized Steel	AC	Aluminum Alloy Cast

**Cooling Tower Systems, Inc.**

196 Lower Cherry Street Macon, GA 31201

TF: 800.752.1905

F: 478.755.8304

www.coolingtowersystems.com

info@coolingtowersystems.com

# PARTS LIST: MODEL T-260

FOR ASSEMBLY DIAGRAM		
Ref. No.	Description	QTY
02-01	Water Sump	1
02-02	Outlet Nozzle	1
02-03	Inlet Nozzle	1
02-04	Over Flow Nozzle	1
02-05	Drain Nozzle	1
02-06	Automatic Filler Nozzle	1
02-08	Float Valve Assembly	1
02-09	Over Flow	1
02-10	Suction Strainer	1
02-12A	Connector	1
02-16	Elbow	1
02-19	Inlet Pipe	1
03-01	Water Basin	2
04-00	Casing Supporter	4
05-01A	Casing	4
05-06	Hand Hole Cover	1
06-01	Stand Pipe	1
06-04	Stand Pipe Base	1
07-01	Stopper	1
08-01	Filling Supporter - A	4
08-02	Filling Supporter - C	4
10-00	Ladder	1
10-03	Ladder Bracket - A	2
10-04	Ladder Bracket - B	2
11-00	Filling	2
12-01	Sprinkler Head	1
12-04	Tension Wire	2
13-01	Sprinkler Pipe	4
13-02	End Cap	4
13-03	Eliminator	4
13-04	Lock Nut	4
14-00	Motor Frame Assembly	1
16-01	Fan Motor	1
16-03	Fan Key	1
16-04	Fasten Nut	1
17-00	Fan Assembly	1
17-01	Fan Hub	1
17-02	Fan Blade	4
17-04	U-Bolt	8
18-01	Fan Guard	2
20-02	Inlet Louver	5
20-03	PVC Frame	10
20-04	Louver Clip	8
20-05	Louver Plate	8
20-06	Lug Plate	8
OTHERS	Bolts & Nuts	1 SET

FOR TECHNICAL DIAGRAMS			
Item No.	Description	Material	QTY
1	Fan Motor	-	1 pcs
2	V-Belt Reducer	-	-
3	Motor Frame Assembly	HDGS	1 set
4	Fan Blade Assembly	AC	1 set
5	Fan Guard	HDGS	1 set
6	Casing	FRP	4 pcs
7	Hand Hole	EVA	1 pcs
8	Sprinkler Head	Nylon	1 set
9	Sprinkler Pipes	PVC	4 pcs
10	Eliminator	PVC	4 pcs
11	Tension Device	-	-
12	Stand Pipe	PVC	1 set
13	Filling	PVC	1 set
14	Stopper or Column	AC	1 set
15	Filling Supporter	HDGS	1 set
16	Casing Supporter	Nylon	4 pcs
17	Inlet Louver	PVC	1 set
18	Frame Assembly	-	-
19	Water Basin	FRP	2 pcs
20	Water Sump	FRP	1 pcs
21	Ladder	HDGS	1 set
22	Strainer	PE	1 pcs
23	Flange	-	-
24	Basin Supporter	-	-

Materials Key	
FRP	Fiberglass Reinforced Polyester
HDGS	Hot Dipped Galvanized Steel
STS	Stainless Steel
AC	Aluminum Alloy Cast
Water Basin Sealing Material	
Fiberglass	1 Set—A
Polyester Resin	1 Keg—B
Catalyst	1 Bottle—C

**Cooling Tower Systems, Inc.**

196 Lower Cherry Street Macon, GA 31201

TF: 800.752.1905

F: 478.755.8304

www.coolingtowersystems.com

info@coolingtowersystems.com



Cooling Tower Systems, Inc.

# ASSEMBLY DIAGRAM: MODEL T-260

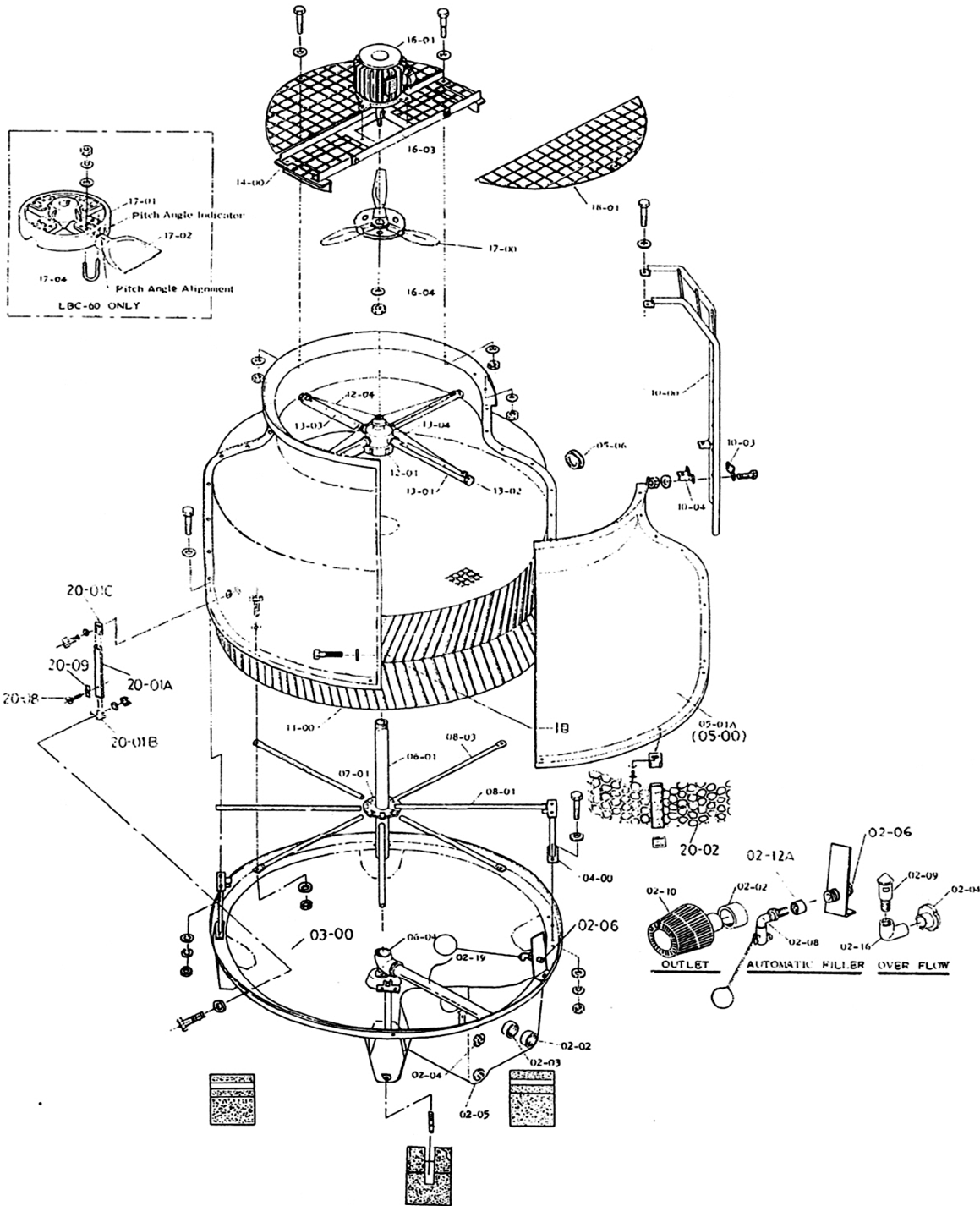

Cooling Tower Systems, Inc.

196 Lower Cherry Street Macon, GA 31201

TF: 800.752.1905

F: 478.755.8304

www.coolingtowersystems.com

info@coolingtowersystems.com

## TECHNICAL IMAGE A: MODEL T-260

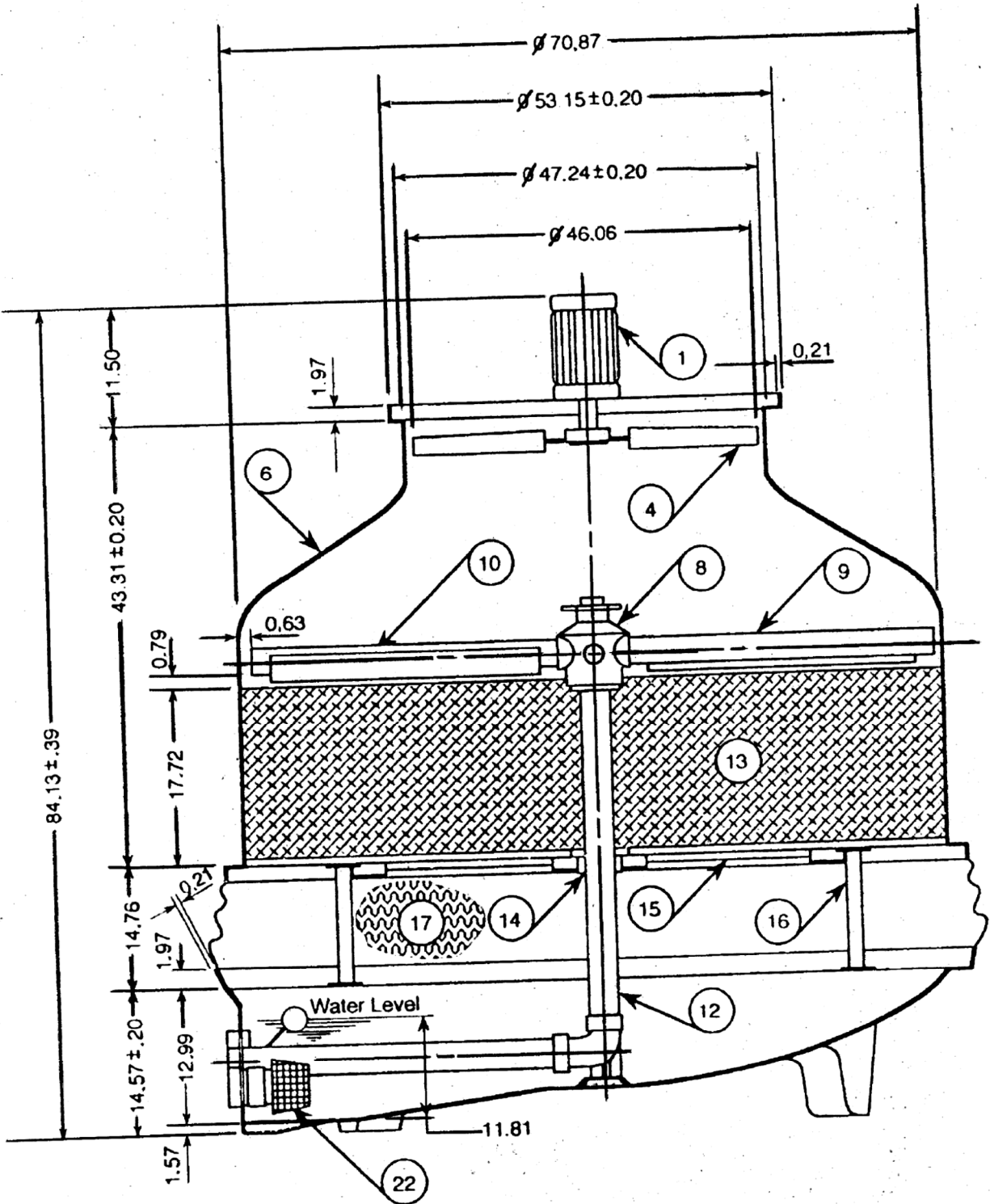

Cooling Tower Systems, Inc.

196 Lower Cherry Street Macon, GA 31201

TF: 800.752.1905

F: 478.755.8304

[www.coolingtowersystems.com](http://www.coolingtowersystems.com)

[info@coolingtowersystems.com](mailto:info@coolingtowersystems.com)



**TACHNICAL IMAGE C & D: MODEL T-260** Cooling Tower Systems, Inc.

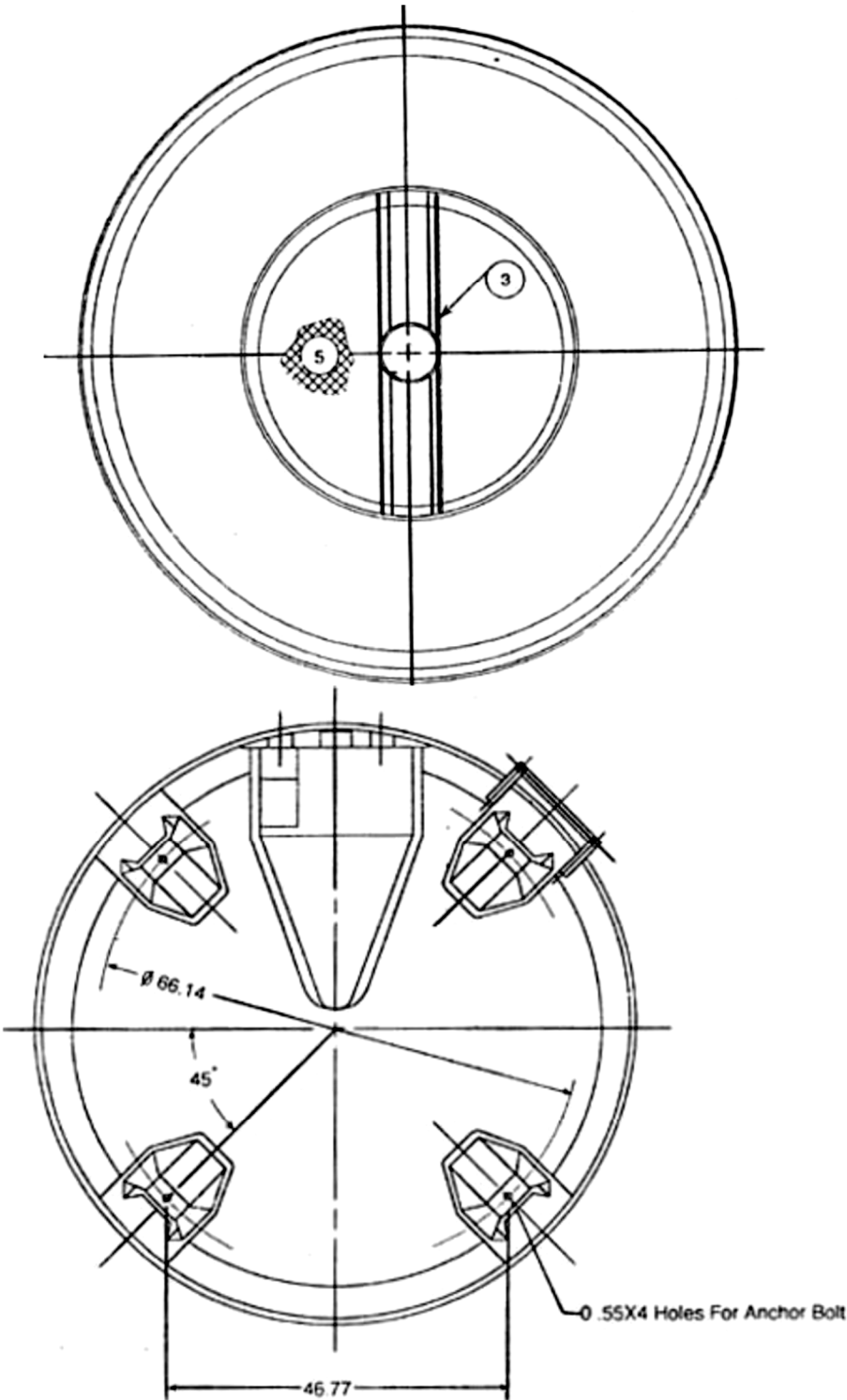

Cooling Tower Systems, Inc.

196 Lower Cherry Street Macon, GA 31201

TF: 800.752.1905

F: 478.755.8304

[www.coolingtowersystems.com](http://www.coolingtowersystems.com)

[info@coolingtowersystems.com](mailto:info@coolingtowersystems.com)

# FOUNDATION DRAWING: MODEL T-260 Cooling Tower Systems, Inc.

T-	øD	W	L TYPE ANCHOR BOLT		
			SIZE	L	PCS
240	57 7/8	40 7/8	W1/2	5	4
250	66 1/8	46 3/4	W1/2	5	4
260	66 1/8	46 3/4	W1/2	5	4

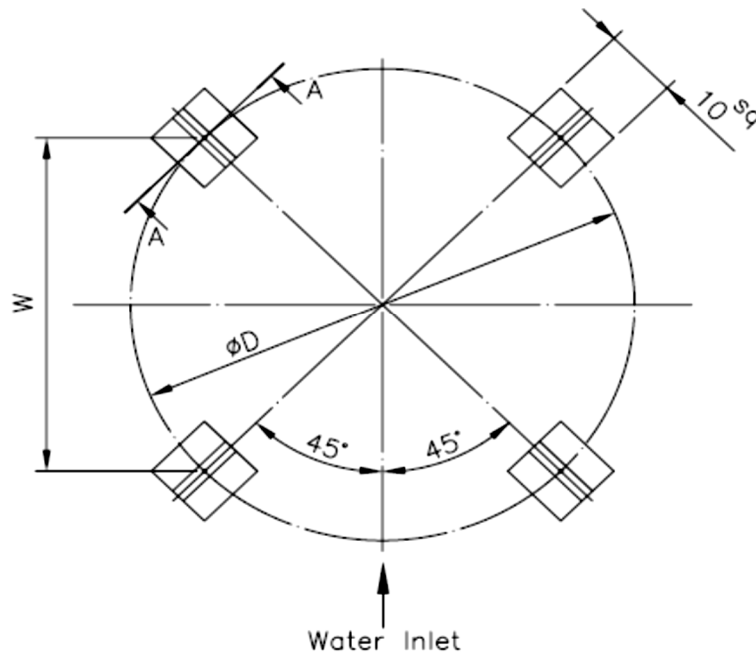

1 1/4" ALL THREAD PROJECTION  
 W1/2x5L, L TYPE ANCHOR BOLT 4PCS

